

# SPECIFICATIONS

## 5 Axle Removable Neck Trailer

**Type:** Low Profile Flat Bed with removable neck.  
**Payload:** 60 tons (120,000 lb) distributed over 16 ft.  
**Overall length:** 59' - 8"  
**Deck length:** 45' - 0"  
**Deck width:** 8' - 6" (102")  
**Deck height:** 3' - 5" (41")  
**Deck camber:** 2" nominal, neck to tail.  
**King pin settings:** 16" and 34"  
**Swing clearance:** 8' - 6" (102") and 10' - 0" (120").  
**Frame:** 4 beam design. Fabricated beams from a A514 T-1 high tensile steel flanges and webs. Main beams boxed reinforced at critical deck transition, 2-1 minimum safety factor at maximum payload stresses.  
**Front deck:** 22'-8" L, 2" apitong attached at ends and every other crossmember.  
**Rear deck:** 22' - 4" L including tail roller, 1/4" steel plate deck, continuous welds on top, intermittent welds on under side.  
**Neck:** Mechanical removable with roller at rear, 2 King Pin locations, spare tire carrier each side  
**Rear Deck Roller:** 8" SCH 160 pipe (8 5/8" OD) with double spherical bearings, 2 sets of over load rollers, grease fittings on main roller and overload rollers.  
**Neck Roller:** 6" SCH 160 pipe (6-5/8" OD) with double spherical bearings, grease fittings, cable guide flanges.  
**Deck Load Rollers:** 6" sch 160 pipe (6-5/8" OD) with double spherical bearings, grease fittings, air operated to raise, spring load to lower, used to assist in unloading skidded loads off the rear.  
**Pin Pockets:** 1 each side at rear on 45 degree angle with 1/2" grab hooks, 2 each side in main deck inside outer beam, 7 each side on outside of outer beam.  
**D Rings:** 15 on each side, outside of outer beam, 2 inside of neck.  
**Outriggers:** 11 each side, forged heavy duty, locking against beam and at 90 degrees to beam  
**Traction Cleats:** 3/4" x 1" A514 T-1 steel, continuous welds solid on up hilltop, intermittent welds on downhill side.

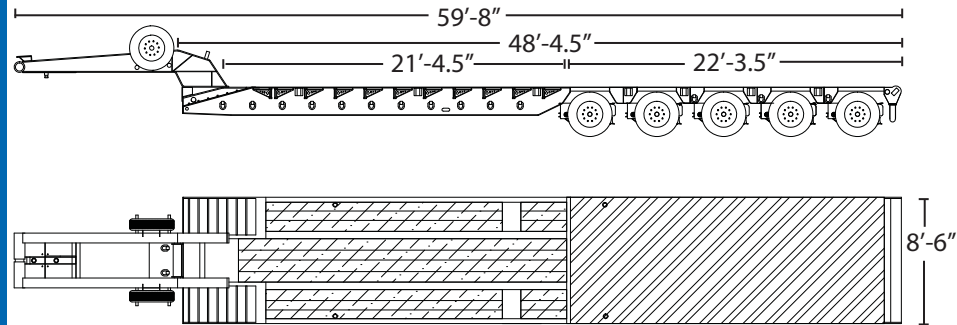

**Suspension:** 30,000 lb (per axle) air ride, air lift on front and rear axles, manual dump all axles, travel limit straps on all axles.  
**Axles:** 5 - 25,000 lb round with outboard drums.  
**Wheels:** 10 hole steel disc hub pilot.  
**Tires:** 255R/70 x 22.5 Radial  
**Brakes:** 16 1/2 x 7, spring parking brakes on 4 axles, auto slack adjusters  
**Bumper:** 4" SCH 80 pipe with 4 - d rings  
**Mud Flaps:** Anti Sail  
**Lights:** Full dot lights, sealed led lights.  
**Coating:** All surfaces near white metal steel grit blast, 2.5 Mil profile (SP-6), primed and color coated (before decking) with high solids polyurethane, 4-6 mil dry film thickness.



# DRAGON

## PRODUCTS, LTD.

# 1-877-235-8194

[www.brucknertruck.com](http://www.brucknertruck.com)