



Date	Group	No.	Release	Page
9.2009	215	88		1(5)

Camshaft Sensor, Replacement

MP7

MP8

MP10

Camshaft Sensor, Replacement

This information covers guidelines for replacing the camshaft sensor on the Mack MP7, MP8 and MP10 engines.

Contents

- "Special Tools", page 2
- "Camshaft Sensor, Replacement", page 3

Note: Information is subject to change without notice.
Illustrations are used for reference only and may differ slightly from the actual engine version. However, key components addressed in this information are represented as accurately as possible.

Tools

Special Tools

The following special tools are used to replace or repair components. The tools can be ordered from Volvo; please use the specified part number when ordering.

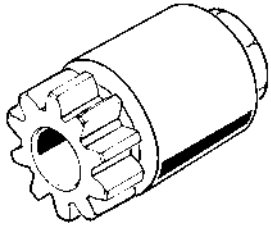

T0012612

88800014

MP8 and MP10 Flywheel Turning Tool

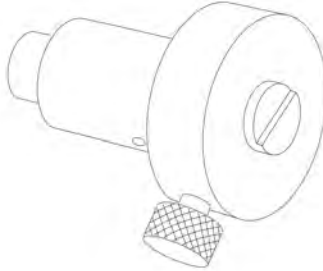

W0002268

88800031

Sensor Depth Gauge



W0001774

9996956

MP7 Flywheel Turning Tool

Service Procedures

2154-03-02-06

Camshaft Sensor, Replacement

You must read and understand the precautions and guidelines in Service Information, group 20, "General Safety Practices, Engine" before performing any procedure. If you are not properly trained and certified in this procedure, ask your supervisor for training before you perform it.

Special tools: 88800014, 88800031, 9996956

Replacement

1

Apply the parking brake and place the shift lever in neutral.

2

Remove all cables from ground (negative) battery terminals to prevent personal injury from electrical shock.

3

Disconnect the camshaft (engine) position sensor harness connector. Remove the retainer screw and remove the sensor from the engine.

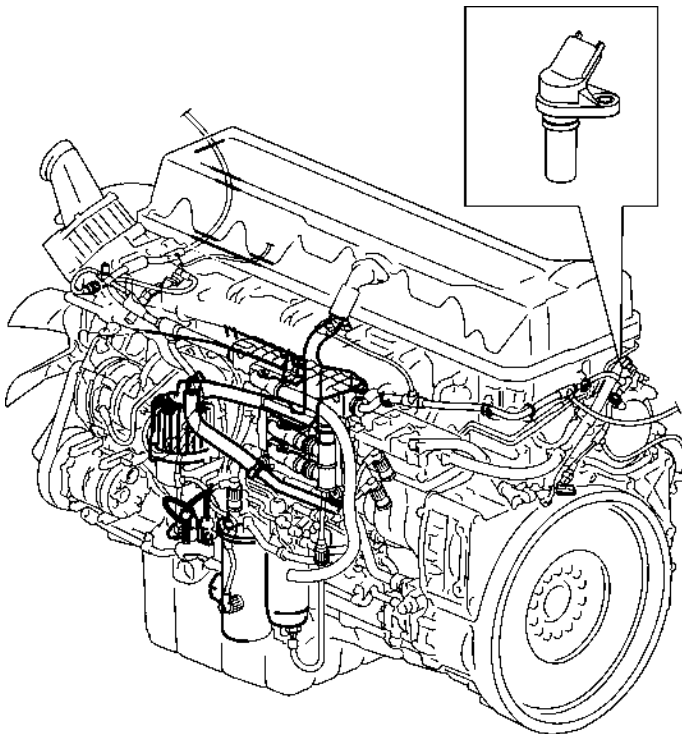

W2033052

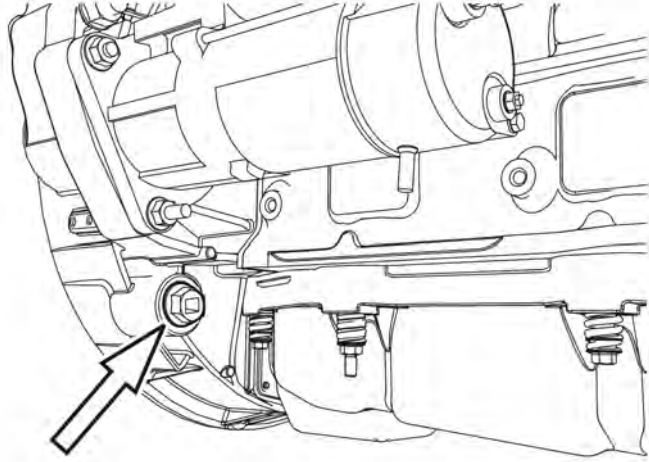

W0002368

4

Install the flywheel turning tool.

88800014, 9996956

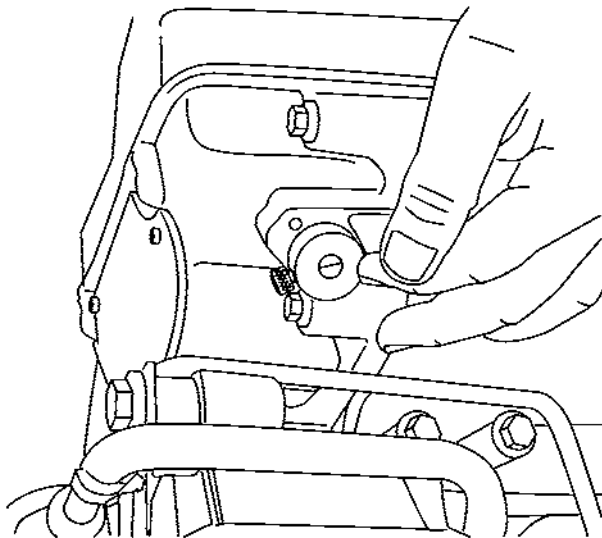

W2005068

5

Check for proper camshaft position sensor clearance using the sensor depth gauge to determine if shims are required for sensor depth. The camshaft position sensor clearance specification is 0.7–1.5 mm (0.02–0.06 inch).

- 1 Rotate the engine until a tooth of the camshaft toothed wheel is aligned with the sensor bore.
- 2 Insert the depth gauge into the sensor bore until the outer part of the gauge is fully seated against the timing gear cover.
- 3 Loosen the thumb screw of the gauge and push the inner part of the gauge in until it contacts a tooth of the toothed wheel.
- 4 Tighten the thumb screw to secure the inner part of the gauge.
- 5 Carefully remove the gauge from the camshaft sensor bore.
- 6 Use a depth micrometer to measure the gauge from the bottom of the gauge collar to the end of the gauge shaft. Record your measurement.
- 7 Determine the number of shims required using the table below.

Measurement	Shims Required
Greater than 35.2 mm (1.39 inch)	0
35.2 — 34.6 mm (1.39 — 1.36 inch)	1
Less than 34.6 mm (1.36 inch)	2

88800031

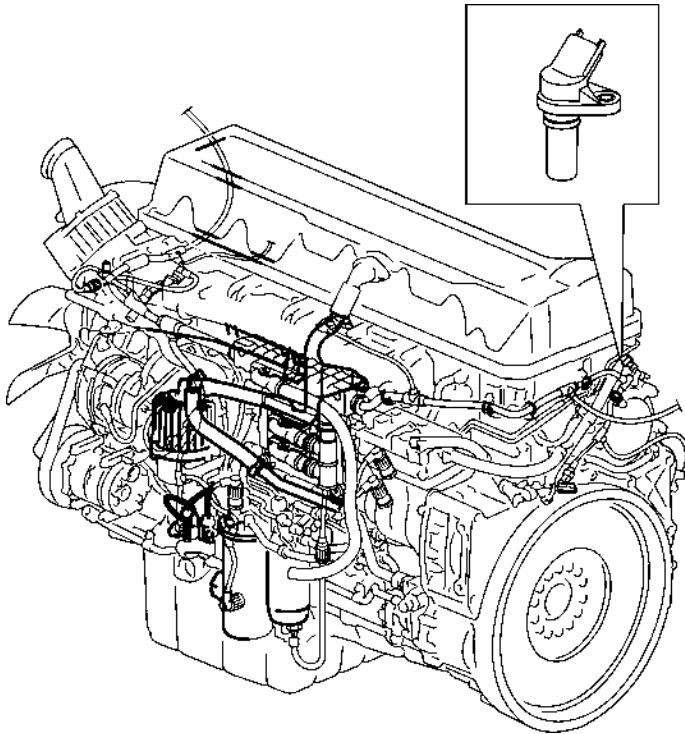

W2033052

6

CAUTION

Use clean motor oil to lubricate the sensor O-ring before installation. If the O-ring is not lubricated before installation, the O-ring may be damaged and an oil leak will result.

Use clean motor oil to lubricate the sensor O-ring before installation. Install the camshaft position sensor with appropriate shim(s) and new lubricated O-ring. Secure with bolt and plug in harness connector.

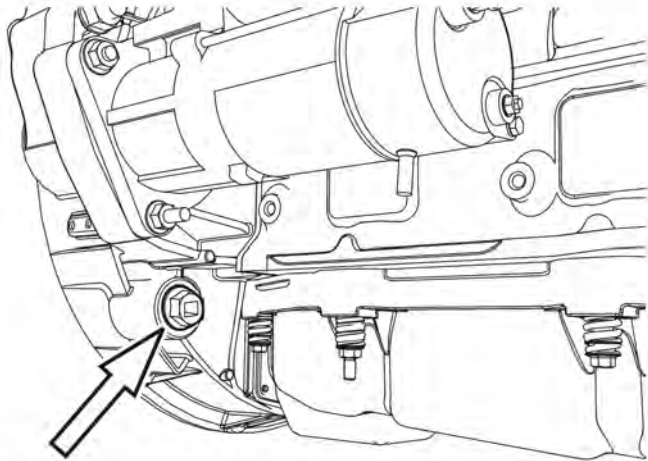

W0002368

7

Remove flywheel turning tool.

88800014, 9996956

8

Install all previously removed cables to the ground (negative) battery terminals.

9

Start the engine, check for leaks and proper operation. Use the diagnostic tool to clear codes.