

# Bruckner's

## TRUCK & EQUIPMENT



### MACK TRUCKS LAUNCHES REFRESHED MACK® MD SERIES

pg 6



**BE SURE TO CHECK OUT THIS  
ISSUE'S PARTS SPECIALS!**



BRUCKNER  
LEASING  
pg 2

TRUCK AND  
TRAILER SPECIALS  
pg 3

PARTS  
SPECIALS  
pg 11

PREVENTATIVE  
MAINTENANCE  
Back Cover



# Bruckner Leasing

Contact the Bruckner Leasing Professional nearest you and learn first-hand the benefits Bruckner Leasing offers and how our leasing and rental options can improve your bottom line.

## FULL SERVICE LEASING

Comprehensive program with benefits that allow you to focus on your business - while we handle the trucks.

## COMMERCIAL RENTALS

From medium duty trucks to tractors, we can help you keep your business running smoothly.

## CONTRACT MAINTENANCE

Whether you have old or newer equipment, we have offerings ranging from Preventative Maintenance to Complete Fleet Service Solutions.



SCAN FOR MORE INFORMATION



# DAY CABS

# INVENTORY SPECIALS



**NEW 2024 MACK MD6 HOOKLIFT**

Cummins ISB6.7 250HP, Allison 6 Spd, GR 5.57, 10K/21K on Multi Leaf, drum brakes, 50-gal fuel tank, SWAP LOADER SL-214 hook lift - 20,000LB lift capacity, Adjustable hook height 35 5/8" or 53 7/8", Roll Rite tarp, chassis mounted lockable storage bins.

**#61497**  
Fort Worth, TX

**\$143,950**



**NEW 2025 MACK GR64FT**

Gold Bulldog! MP8 415HP, mDrive HD, 14.6K/40K on mRide, 224" WB, Kompensator Fixed 5th Wheel.

**#65885**  
Tye, TX

**PLEASE CALL**



**NEW 2025 MACK MD7 SERVICE TRUCK**

ISB6.7 300HP, Allison 6 spd, Stellar TMAX2-11 Aluminum Mechanics Body by Curry Supply Co, American Eagle Compressor- 46CFM, Stellar 12621 Telescopic Crane-12K Capacity. Chassis is MD7 but has been derated at the factory to 25,995GVW (Non CDL)

**#65082**  
Denver, CO

**\$222,279**



**NEW 2025 MACK GR64F DUMP TRUCK**

MP8 455HP, mDrive HD 13 Spd, 18K/46K, Diff Locks, 18' Rogers aluminum dump bed w/ 70" side height, electric tarp and 20K non-steerable lift axle. CARB+EPA. Price includes FET.

**#65268**  
Pottsville, AR

**\$263,870**



**NEW 2025 VOLVO VNR300**

D13 405HP, I-Shift, Dynamic Steering, VADA 2.0, 12K/40K, Disc Brakes, 170" WB, Pintle Hook, FedEx Spec. Price includes FET.

**#65214**  
Shreveport, LA

**\$169,500**



**NEW 2024 HINO L7**

Cummins 6.7 260HP, Allison 3500 RDS 6 Spd. 14k Front, 23k rear axle with spring suspension. Chassis will have a Hilbilt Dump bed installed on it.

**#64191**  
Lowell, AR

**PLEASE CALL**



**USED 2020 MACK PI64T**

MP8 445HP, mDrive HD, Engine Brake, 12K40K on Air Ride, Dual Exhaust, 213" Wheelbase, Disc Brakes, New 245 Rubber on Aluminum Wheels, 237,035 Miles.

**#A9911P**  
Fort Worth, TX

**\$96,900**



**USED 2019 KENWORTH W900L**

X15 565HP, 18 Spd Manual, 13.2K/40K on Air Ride, 238" WB, 3.9 ratio, Full Gauge Package, New Driver Seat, New 11R24.5 Drive tires, 390,614 miles.

**#B0133P**  
Oklahoma City, OK

**\$119,500**



**USED 2017 FREIGHTLINER CASCADIA 125**

DD13 435HP, DT12, 12K/40K on Air Ride, 178" WB, 3.25 Rear, 397,317 miles

**#B0114P**  
San Antonio I-10, TX

**\$34,990**



**NEW 2024 VOLVO VNL860**

D13 455HP, I-Shift, VADA 2.0, 13.2K/40K, 2.64 Rears, Front Disc Brakes, 237" WB, Leather Seats, Bunk Heater, Dbl Bunks, Workstation, Fridge, Inverter, Infotainment w/ Navigation. CARB + EPA. Price includes FET.

#61098

Wichita Falls, TX

**\$184,800**



**NEW 2023 MACK GRANITE SLEEPER**

MP8 505HP, mDrive, Sleeper equipped with folding table that converts to a bed, sink with running water, fridge and microwave. Loads of storage space in this unit. Custom bumper, cab skirt lights and stacks. Price includes FET.

#59419

Fountain, CO

**\$274,799**



**NEW 2024 MACK AN64T70**

MP8 445HP, mDrive, CARB+EPA, 12K/40K on Air Ride, Battery Lifeguard System, Command Steer, 227" WB, Air Weigh Monitoring System, Speed Limit Sign Recognition, Bendix Fusion 2.0 Front And Side Warning System, Data Capture, Infotainment + Premium Stereo, Back-Up Camera with Navigation, Inverter, Refrigerator. Price includes FET.

#63469

Odessa, TX

**\$185,500**



**NEW 2025 VOLVO VNL860**

Globetrotter XL: D13 500HP, I-Shift (vocational), 12.5K/46K with Diff Locks, Dynamic Steering, Bunk Heater, Workstation, Fridge, Inverter, Battery-Powered Parking Cooler. CARB + EPA. Price includes FET.

#64782

Farmington, NM

**\$203,972**



**NEW 2024 VOLVO VNL860**

D13TC 455HP, I-Shift, VADA 2.0, Bunk Heater, Battery-Powered Parking Cooler, Fridge, Inverter, Workstation, AC/Heated Massage Leather Seats, Michelin Tires, Davco Heated Fuel Water Separator, Disc Brakes, Shore Power. Price includes FET.

#63860

Wichita, KS

**\$204,900**



**NEW 2025 VOLVO VNL760**

D13TC 455HP, I-Torque I-Shift, Bunk Heater, Double Bunk, Fridge, Inverter, TV & M/W Prep Kits, Position Perfect Steering Wheel. Price includes FET.

#64571

Lubbock, TX

**\$189,580**



**USED 2023 PETERBILT 389**

X15 565HP, 18 Spd Manual, 280" WB, 6 Wheel Disc Brakes, 3.25 Ratio on LoPro 22.5's, Fridge, Dual Air Ride Ultra Leather Seats, 231,525 mi.

#B0249P

Oklahoma City, OK

**\$164,900**



**USED 2020 KENWORTH T880**

X15 450HP, Advantage 10 Spd, 13.2K/40K on Air Ride, 252" WB, Disc Brakes, 430K miles.

#B0360P

San Antonio I-10, TX

**\$75,990**



**USED 2019 VOLVO VNL62T760**

D13 405HP, I-Shift, Disc Brakes, Double Bunk, Inverter, Dual 125 Gal Fuel Tanks, TV & M/W Prep Kits, Fleet Maintained, 640,663 mi.

#B0265

Fort Worth, TX

**\$35,950**

# TRAILERS NEW AND USED

## INVENTORY SPECIALS



**NEW 2024 TROXELL 130BBL**

Heavy Duty 1/4 Barrel, Interior Lining, Walkway, Extra Front Manway, Single Point Suspension, Rear Sight Glass, 11R 24.5 With Steel Disc Wheels. Price includes FET.

---

**#64164** **\$72,860**  
Hobbs, NM



**NEW 2023 CTS SCRAPMASTER**

40' Frameless Demolition Scrap Trailer with 100" Sides. Hutch Center Point suspension. 11R24.5 Sumitomo Tires on Steel Wheel. Mountain Electric Tarp. Swing Open Barn Door. Price includes FET.

---

**#59245** **\$85,120**  
Tye, TX



**NEW 2024 TRAILBOSS TAG-ALONG**

25-Ton Dovetail Tag-A-Long with fold down spring-assist ramps. 27' Deck with 5' Dovetail. Price includes FET.

---

**#60237** **\$47,040**  
Van Buren, AR



**NEW 2024 CTS HRD28**

28' Rock Master Quarter Frame Half-Round End Dump, 1/4" Tub, Double Hinge Tailgate, 6" Spreader Apron, 4 Alum Wheels. Price includes FET.

---

**#63608** **\$64,950**  
Big Cabin, OK



**NEW 2024 TALBERT 55 TON**

53' 3" length. Pony Motor, connections for PTO. Deck section length 26'-6" (26'-0" clear) without removable rear ramp. 24'-6" (24'-0" clear) with rear deck ramp in place. loaded deck height 20". Outriggers 12" swinging/removable. 3 AXLES, AXLE capacity 25,000-GAWR 24,700. Axle spacing 54". Wheels 10 stud. Manual raising & Lowering (+3"/-3"). Fenders 1/4" floor plate over tires only. Connection for future removable Axle. 12 D RINGS. Price includes FET.

---

**#63915** **\$133,280**  
Enid, OK



**NEW 2024 FONTAINE FLATBED**

FONTAINE 45' Flat Bed Trailer. GVWR 70,333. Includes Stainless Steel Lock Box. Price includes FET.

---

**#63524** **\$62,160**  
Tulsa, OK



**NEW 2024 FONTAINE MAG55**

55 Ton 22" Loaded Deck Height Self Contained Hydraulic Detach Lobby. 7 Position easy to hook up and adjust. Specs include 26" Free and Clear Flat Level Deck. Load Bearing Fender Covers, front flips ramps. 60" Spacing on the rear bogie with included 4th Axle. Outside Aluminum Wheels 23" Front Flip Box is also included. Air Lift 3rd Axle and Strobe Lamp Package that operates with the neck detached for safety. Price includes FET.

---

**#61948** **\$168,000**  
Yakima, WA



**NEW 2023 TROUT RIVER LIVE BOTTOM ASPHALT TRAILER**

41' Insulated, 30CY Capacity water level or 34 Yards Heaped. 11R24.5 Tires on Outer Aluminum Wheels. 50" Axle Spacing Hendrickson Intraxx AA250 Air Ride, 11 gauge AR400 Walls, High Lift Air operated Tailgate. High Arc Electric Vinyl Tarp. Price includes FET.

---

**#57340** **\$104,160**  
Fort Worth, TX



**USED 2021 HICKS SL3932**

Aluminum End Dump, UHMW extra wide liner, Lift Axle, Ridewell RAR266 Air Ride, Inside width 77", Side Height 44", Capacity 32 Yards, Rollover tarp.

---

**#B0096P** **\$38,500**  
Fort Worth, TX



# MACK TRUCKS LAUNCHES REFRESHED MACK<sup>®</sup> MD SERIES

Mack Trucks recently announced a significant refresh of its Mack<sup>®</sup> MD Series diesel and electric medium-duty trucks, featuring a larger cab that improves the driver environment and incorporates new safety features. These updates further strengthen Mack's medium-duty offering to meet evolving customer needs and applications.

“The launch of the refreshed Mack MD Series once again demonstrates Mack's commitment to delivering the best medium-duty truck for our customers,” said Jonathan Randall, president of Mack Trucks North America. “Since the MD Series was introduced in 2020, Mack has continued to listen to our customers and make ongoing improvements to meet their operational needs.

The Mack MD Series is available with diesel or electric drivetrain options in the MD6, a Class 6 model with a Gross Vehicle Weight Rating (GVWR) of 25,995 pounds, and the MD7, a Class 7 model with a GVWR of 33,000 pounds. Both models are exempt from the 12% Federal Excise Tax (FET).

These key updates – now standard on the MD without raising its price – include enhanced driver comfort and safety features, while improving ease of installation for body builders. The biggest change is that the MD's cab is now four inches longer than the previous version,

which gives drivers more seat recline and leg room. This refreshed cab further shows how the Mack Anthem<sup>®</sup> cab influenced the MD cab design and many of the shared driver-comfort features, such as an overhead console for additional storage. The interior boasts premium satin aluminum trim, improved seating with lumbar support and enhanced LED lighting. New steering wheel controls for cruise control, telephone and audio functions have been added, increasing driver convenience and safety. All of these have been popular with Mack's Class 8 customers.

The trucks now come standard with several enhanced safety features including new ABS (Anti-Lock Braking System) with ATC (Automatic Traction Control), radio mute in reverse and a park brake alarm.

Pre-wired body builder connections relocated air dryer and updated wheelbases to industry-standard Cab to Axle (CA) dimensions make the updated MD Series easier to install an even wider array of body installations than previously.

“The MD Series continues to build on the success of our initial medium-duty offering,” Randall said. “Built with Mack's heritage of reliability, these enhancements will provide a more versatile and efficient truck, across a wide range of applications.”



Key updates include enhanced driver comfort and safety features, while improving ease of installation for body builders. The MD's cab is now four inches longer than the previous version, which gives drivers more seat recline and leg room. This refreshed cab further shows how the Mack Anthem® cab influenced the MD cab design and many of the shared driver-comfort features.

**Mack's commitment to improvement in the product is further proof that class 6 and class 7 customers can enjoy the iconic brand that class 8 customers have enjoyed for 125 years."**

**Michael Roquemore**  
Bruckner's Corporate Mack Sales Manager

"I am super excited for the MD cab refresh especially for our customers," says Michael Roquemore, Bruckner's Corporate Mack Sales Manager. "This gives the driver more space for reclining the seat and a little leg room. They now get a class 8 truck seat option and more room for those 3 man crews that work hard in the elements all day and want to relax with a little more space when they are headed out or back from the job. Since the launch of the MD product a few years ago, Mack has committed to improvements in driver safety and comfort. They have also committed to helping body builders, upfitters and mechanics work more efficiently with the added PTO overlay and switch options and body builder harnesses.

The medium duty truck has been a great product for the Bruckner's organization. We have enjoyed getting to know the medium duty market and customer needs. We will continue to grow our market share with this product and Mack's commitment to improvement in the product is further proof that class 6 and class 7 customers can enjoy the iconic brand that class 8 customers have enjoyed for 125 years."

Customers interested in the refreshed Mack MD Series models can contact their local Bruckner's Sales & Equipment dealer and sales representative or visit <https://www.brucknertruck.com> for more information.





**MACK TRUCKS**

**No. 1** **IN CUSTOMER SATISFACTION\***

\*Based on a 2023 survey of North American heavy duty (Class 8) truck owners.

## **INNOVATION, RELIABILITY, AND UNMATCHED PERFORMANCE FOR YOUR JOURNEY – OUR COMMITMENT SETS THE GOLD STANDARD.**

Dedicated to durability, reliability and meeting the needs of customers, Mack Trucks has provided purpose-built transportation solutions for more than a century.

Today, Mack is one of North America's largest producers of heavy-duty trucks, and Mack® trucks are sold and serviced through an extensive distribution network in more than 45 countries. Mack trucks, diesel engines and transmissions sold in North America are assembled in the United States. Mack manufacturing locations are certified to the internationally recognized ISO 9001 standard for quality, ISO 14001 standard for environmental management systems and ISO 45001 standard for health and safety management systems. Mack is also a proud sponsor of Share the Road, an American Trucking Associations public information campaign aimed at enhancing the safety of our nation's roadways.

Mack Trucks is part of the Volvo Group, which is driving prosperity through transport and infrastructure solutions, offering trucks, buses, construction equipment, power solutions for marine and industrial applications, financing and services that increase customer uptime and productivity. Founded in 1927, the Volvo Group is committed to shaping the future landscape of sustainable transport and infrastructure solutions. The Volvo Group is headquartered in Gothenburg, Sweden, employs about 104,000 people and serves customers in almost 190 markets. In 2023, net sales amounted to about \$52 billion. For more information, please visit [www.volvogroup.com](http://www.volvogroup.com).

For more information about Mack, visit our website at [www.macktrucks.com](http://www.macktrucks.com)



**Bruckner's**  
TRUCK & EQUIPMENT



**POWERON.**



Call Bruckner's  
of Albuquerque at  
(505) 843-7703 for  
more information

2025 HINO L7  
Stk # 65505

The Hino Trucks' conventional models have been the fastest growing medium duty trucks for years. It started with great aerodynamics, functionality, durability, and has continued to develop their telematics services, Hino Edge, which is among the best telematic service in the industry. The Hino Trucks L Series sports an automotive grade interior, a host of new advanced safety equipment, and larger cab configurations for more versatility than ever before. Available in day, extended, and crew cab configurations Hino Trucks L Series trucks are ideal for applications ranging from 23,000 to 33,000 lbs. GVWR. - POWER ON.

**V O L V O**



Introducing the all-new  
**VOLVO VNL**  
Totally re-imagined and  
improved in every aspect

*The all-new Volvo VNL features the next generation of enhancements to improve total customer value, driver productivity, safety, and sustainability.*

Speak to your Bruckner Representative for more information.



**BTE OF IRVING**  
800.634.5619  
1601 E. State Hwy 356  
Irving, TX 75060

**BTE OF PHOENIX**  
602.278.9227  
2650 N. 32nd Ave  
Phoenix, AZ 85009

btebody.com



**2024 Mack MD7**

*Including  
mounted  
Pac-Mac  
KB-20 Grapple*

*6 Units Available!*

**\$223,482**

PARTS | SERVICE | EQUIPMENT SALES



# Bruckner Finance

## **REASONS YOU SHOULD CONSIDER UTILIZING BRUCKNER'S FINANCE DEPARTMENT**

- ✓ **Convenient "application only" credit process (for transactions up to \$1,500,000)**
- ✓ **Quick credit decisions, often times same day**
- ✓ **Minimal down payment including \$0 down and/or 72 month amortization loans available**
- ✓ **Token payment options available for seasonal operation**
- ✓ **FMV and TRAC Leases available**
- ✓ **Lines of credit for future equipment purchases available — keeping bank lines open for working capital needs**
- ✓ **Refinance options to assist with cash flow during economic down-turns**
- ✓ **Competitive rates, flexible terms**
- ✓ **Convenient "One Stop Shopping" with experienced, industry professionals**



**SCAN QR CODE TO  
COMPLETE YOUR ONLINE  
APPLICATION TODAY!**

**Joe Brown**  
Corporate F&I Manager  
7626 Brighton RD  
Commerce City, CO 80022  
(303) 931-2857  
joe.brown@brucknertruck.com

# OIL PRODUCTS



Lucas Oil understands the challenges that heavy duty truckers and freight operators face every day. That's why we have developed a range of top-quality oil additives specifically designed to meet the demanding needs of the trucking industry. With Lucas products, you can enhance the fuel efficiency, performance and reliability of your heavy duty fleets, ensuring they go the extra mile without the extra budget.



### Fuel Treatment

Cleans and lubricates the fuel system  
Neutralizes low sulfur fuel problems

#10013 - 1-Gallon  
**\$25.29**



### Pure Synthetic Oil Stabilizer

Increase oil life by at least 50%  
Reduces oil consumption  
Eliminates dry starts

#10130 - 1-Quart  
**\$15.81**



### Synthetic Sae 75W-90 Gear Oil

Heavy duty  
High performance

#10047 - 1-Quart  
**\$14.35**



### Heavy Duty Oil Stabilizer

Increases power and miles per gallon

#10011 - 1 Quart  
**\$10.28**



### Red "N" Tacky Grease

Rust and oxidation inhibitors  
Water resistant  
Excellent mechanical stability

#10676 - 2.5oz  
**\$2.15**



### High Mileage Oil Stabilizer

Excellent at fighting oil sludge  
Raises oil pressure  
Lubricates all internal parts to minimize wear

#10118 - 1 Quart  
**\$11.07**



### Heavy Duty 80W-90 Gear Oil

Contains special anti-wear and lubricity agents  
Helps to control heat

#10043 - 1 Quart  
**\$7.25**



### Heavy Duty Oil Stabilizer

Increase oil life at least 50% longer  
Reduces oil consumption  
Eliminates dry starts  
Raises oil pressure

#10002 - 1 Gallon  
**\$32.47**



### Slick Mist Detailing Kit

Interior detailer (24oz 710ml)  
Tire & trim shine (24oz 710ml)  
Speed wax (24oz 710ml)  
Microfiber towel (16" x 16")

#10558  
**\$29.60**



### Hub Oil

Slow leaks  
Prevents downtime  
Extremely heat resistant  
Long lasting

#10088 - 32oz  
**\$7.12**



### 5th Wheel and Slider Lube

A clean, inexpensive alternative to grease for 5th wheels and sliders.

#10030 - 1 Pint  
**\$6.44**



### Synthetic Brake Fluid Dot 4

Prevents seal hardening or softening  
Protects against rust or corrosion  
Excellent lubricity

#10827 - 12oz  
**\$3.56**

# A/C PRODUCTS



**ROAD CHOICE**  
TRUCK PARTS



## FREIGHTLINER

2010 - 2020 Cascadia 113, 125  
models w/DD13/15/16

**\$ 394.46**

Compressor  
ACC1274 OE# 22-65771

**\$ 65.97**

Drier  
RD11222 OE# A22-77123-003

**\$ 43.96**

Expansion Valve  
EV01435 OE# T1000898P

**\$ 186.24**

Condenser  
CON0429 OE# A22-72495-000 (Day Cab)

**\$ 191.31**

CON0431 OE# 22-62272-000 (Sleeper)



## FREIGHTLINER

2018 thru 2024 Cascadia 116 126  
models w DD13 15 16

**\$ 394.46**

Compressor  
ACC1274 OE# 22-65771

**\$ 42.26**

Drier  
RD11225 OE# A22-77123-003

**\$ 29.64**

Expansion Valve  
EV01447 OE# B0AGH882001

**\$ 169.29**

Condenser  
CON0439 OE# A22-72869-000 (Day Cab)

**\$ 164.21**

CON0438 OE# A22-72870-000 (Sleeper)



## INTERNATIONAL

2011 - 2017 Prostar Day Cab  
models w/A26 Navistar engine

**\$ 285.13**

Compressor  
ACC4476 OE# 3808548C1

**\$ 90.19**

Drier  
RDP1220 OE# 3839360C92

**\$ 33.71**

Expansion Valve  
EV01360 OE# 3857948C2

**\$ 233.43**

Condenser  
CON0649 OE# 2604851C91



## INTERNATIONAL

2018 - 2023 LT625 models  
w/Cummins X15 engine

**\$ 310.06**

Compressor  
ACC3388 OE# 3863068C1

**\$ 33.71**

Drier  
RD15380 OE# 2517315C91

**\$ 33.56**

Expansion Valve  
EV01171 OE# 2516574C91

**\$ 169.29**

Condenser  
CON0656 OE# 2518753C91



*\*Images above may not necessarily depict the exact part number*

## HEAVY DUTY A/C SERVICE ITEMS AVAILABLE

ROAD CHOICE



PRODUCT CATALOG



# A/C PRODUCTS



## PACCAR

2008 - 2014 T600, T800 models  
w/ Cummins X12X15 engine

**\$ 303.83**

Compressor  
ACC3609 OE# F69-6003-122

**\$ 26.42**

Drier  
RD12325 OE# K251-571; K251-591

**\$ 28.71**

Expansion Valve  
EV01025 OE# 540446

**\$ 218.24**

Condenser  
CON0827 OE# N4783001



## PACCAR

2010 - 2021 389 models  
w/Paccar MX11 & MX13 engine

**\$ 334.89**

Compressor  
ACC4503 OE# F69-1018-141

**\$ 39.81**

Drier  
RD11108 OE# F37-6009 (Day Cab)

**\$ 39.64**

Drier  
RD11107 OE# F37-6008 (Sleeper)

**\$ 37.18**

Expansion Valve  
EV01150 OE# 35011516

**\$ 225.18**

Condenser  
CON1233 OE# N4778001



## PACCAR

2014 - 2020 KW T680, T880 & PB 579  
w/MX11 & MX13 engine

**\$ 334.89**

Compressor  
ACC4503 OE# F69-1018-141

**\$ 50.47**

Drier  
RD11110 OE# F37-1017-200 (Day Cab)

**\$ 50.72**

Drier  
RD11109 OE# F37-1017-100 (Sleeper)

**\$ 65.28**

Expansion Valve  
EV01180 OE# 1000478038

**\$ 279.39**

Condenser  
CON0828 OE# Z9206001



## PACCAR

2013 - 2021 KW T680, T880 & PB 579  
w/Cummins X15 engine

**\$ 334.89**

Compressor  
ACC4502 OE# F69-1015-111

**\$ 50.47**

Drier  
RD11110 OE# F37-1017-200 (Day Cab)

**\$ 50.72**

Drier  
RD11109 OE# F37-1017-100 (Sleeper)

**\$ 65.28**

Expansion Valve  
EV01180 OE# 1000478038

**\$ 279.39**

Condenser  
CON0828 OE# Z9206001



*\*Images above may not necessarily depict the exact part number*

## HEAVY DUTY A/C SERVICE ITEMS AVAILABLE



ROAD CHOICE



PRODUCT CATALOG

# TANK TRUCK EQUIPMENT ENGINE PARTS



100% Associate Owned

D&W is an employee-owned remanufacturer and national distributor of engine parts, and tank truck equipment for light, medium, and heavy duty all-makes applications, inclusive of on and off-highway vehicles.

## TANK TRUCK EQUIPMENT

### PUMPS & PARTS



Roper



Blackmer



Maintenance Kit



FloTech Monitor

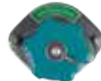

FloTech Thermistor



Betts



Emco



Civacon

### ENGINEERED PACKAGES



PCM



PCC

### REMANUFACTURED TRUCK BLOWERS



Gardner Denver



Drum

## DIESEL ENGINE AND AFTERTREATMENT COMPONENTS



High Pressure Oil Pumps



Injection Pumps



Injectors



Air Compressors



Supply Module



Doser Injector



EGR Cooler



EGR Valve



DEF Header

# PARTS SPECIALS



## COMMAND EXTENDED NITRITE FREE

4771-AFC13100F  
RED-50/50 | Gallon

Single Case  
**\$7.75 \$7.46**



## COMMAND EXTENDED

4771-AFC11100F  
RED-50/50 | Gallon

Single Case  
**\$8.43 \$8.12**



## WINDSHIELD WASHER FLUID

4771-AS658  
Delux 3-in-1  
6 per case

Single  
**\$4.88**

## STANDARD BEAM

2403W  
E-track shoring beam adjusts from 96"-104"  
Load capacity 2000lbs

**\$48.75**



## HEAVY DUTY BEAM

2403WWHD-PE  
E-track shoring / decking beam adjusts 96"-104"  
Load capacity 3000lbs

**\$89.99**



## DELCO 24SI Alternators

8600310  
24 SI New Alternator

8600889  
24 SI New Alternator

**\$237.99**



## STANDARD BRAKE CHAMBER

S-16987 3030

**\$44.00**



## Legacy SILVER 188900 MW61

HB BLACK DURALEASE™

**\$784.42**

## Heritage SILVER 189800 FA635

HB 20" 15D 2W GRAY TUFFTEX

**\$544.48**



188900

## BATTERIES FOR ALL MAKES AND MODELS

MVL31X  
CCA 925

**\$90.97**

M311000  
CCA 1000

**\$99.97**

V31HC730  
Dual Cycle Battery

**\$111.21**



Prices good through Aug 2024  
with good core exchange.

*\*Images above may not necessarily depict the exact part number*



# USED TRUCK PARTS



## EXTENSIVE SUPPORT FOR ALL YOUR TRUCKS!

New, Used, Remanufactured, Reconditioned, Recycled

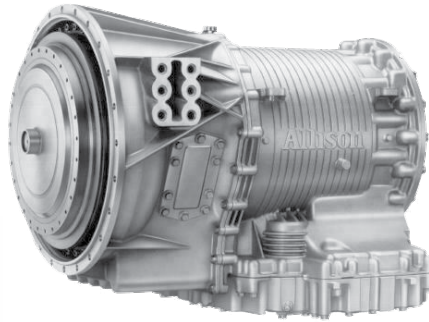

**ENGINES | TRANSMISSIONS  
DIFFERENTIALS | HOODS | CABS**

**ALL MAKES RECYCLED PARTS**  
*AVAILABLE AT BRUCKNER'S*



# EZ SERIES CLUTCHES



## 15.5" CLUTCH ASSEMBLY FEATURES

Road Choice offers medium and heavy-duty self-adjust and manual-adjust clutches to meet your customer's needs. Every Road Choice clutch utilizes cryogenically treated disc springs for longer life, crimped sleeve bushings that help with misalignment issues, and a sealed release bearing to prevent contamination.

**Road Choice EZ Series Clutch requires 25% less pedal effort.**

**Friction material is asbestos-free woven organic and sintered copper materials.**

**Fiber spacer free of charge in every new Road Choice clutch unit.**

**No cores to handle; new parts and assemblies are used.**

**24-Month and unlimited mileage warranty.**

**Made in the USA.**

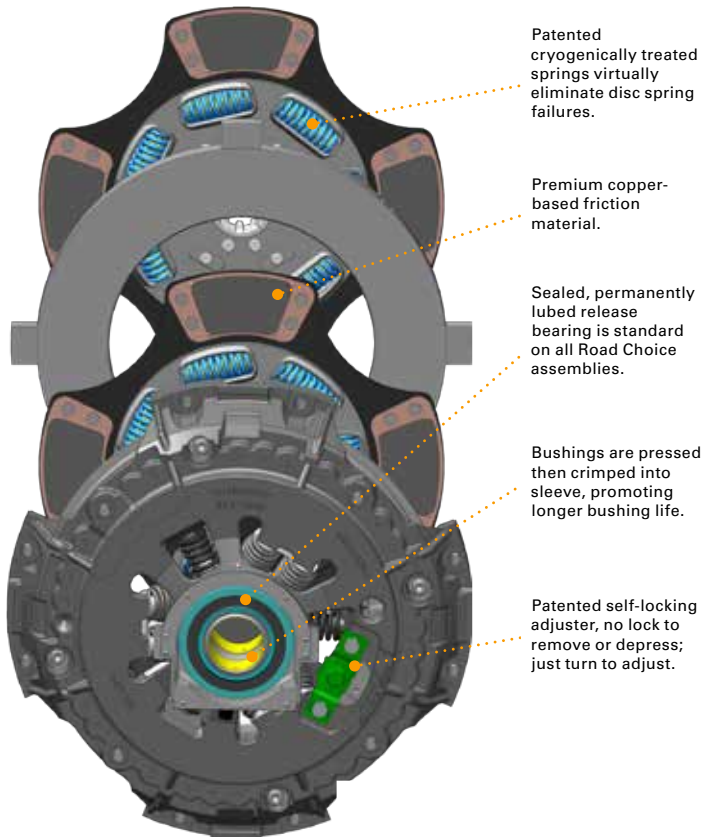

PART #	DESCRIPTION	CROSS REFERENCE	PRICE
CLU20892582	CLUTCH, 15.5X2, 7SPR 6PDL C	108925-82AM	\$589.26
CLU20892525	CLUTCH, 15.5X2, 7SPR 6PDL N	308925-25	\$747.39
CLU20892582H	CLUTCH, 15.5X2, 7SPR 6PDL N	108925-25AM	\$644.78
CLU20893551	CLUTCH, 15.5X2, 9SPR 6PDL C	108935-61MO   308925-51   308925-68	\$626.12
CLU20893551H	CLUTCH, 15.5X2, 14SPLINE, 7S	308925-91   308925-91	\$685.08
CLU10723710	CLUTCH, 14X2 SS, 8SPR 3PDL	107237-10	\$542.16
CLU20839174	CLUTCH, 15.5X2, 8SPR ORGNC	108391-74AM	\$557.91
CLU20993551H	CLUTCH, 15.5X2 SA, 7SPR 6PD	309701-98	\$951.25

# WHEEL END AND STEERING



## MAKING THE ROADWAYS SAFER

Safety is our guiding belief, our true north. It's what drives us to engineer products that are safer and inherently better because they last longer, perform exceptionally and save you money. That's what you get when you put safety first.



### Auto-Torq<sup>®</sup> Axle Fastener

STEMCO is changing the game on wheel ends again. With the Auto-Torq axle fastener, installation has never been easier. Auto-Torq sets the wheel end in optimum bearing adjustment for maximum life.

### Discover<sup>®</sup> XR

True innovation for the wheel seal market. Equipped with patented GlideLock technology.



### QwikKit<sup>®</sup> King Pin Kits

Keeping fleets on the road longer. Trust the King Pin Experts! Designed for durability and tested for toughness.



### QwikTie<sup>®</sup>

Highly adaptable for maximum efficiency. Patented design increases simplicity and safety. STEMCO QWIKTIE offers a highly adaptable solution that can accommodate over 80% of straight tie rod lengths with just two part numbers.





SCAN FOR  
FULL LOCATION  
LISTINGS



# DEDICATED TO YOUR UPTIME

## MULTIPLE LOCATIONS ACROSS 8 STATES

### TEXAS

#### **AMARILLO**

(866) 348-MACK  
9471 I-40 East Exit #76  
Amarillo, TX 79118

#### **BRIDGEPORT\***

*(PARTS ONLY LOCATION)*  
(877) 729-MACK  
401B 13th Street  
Bridgeport, TX 76426

#### **CLEBURNE\***

*(PARTS ONLY LOCATION)*  
(866) 411-MACK  
1744 N. Main St., Suite A  
Cleburne, TX 76031

#### **DALLAS (Irving Blvd.)**

(877) 999-8092  
3611 Irving Boulevard  
Dallas, TX 75247

#### **DALLAS (I-20)**

(877) 999-8078  
35680 LBJ Freeway  
Dallas, TX 75241

#### **FORT WORTH**

(866) 350-MACK  
1200 N.E. Loop 820  
Fort Worth, TX 76106

#### **LUBBOCK**

(866) 358-MACK  
1125 E. Slaton Highway  
Lubbock, TX 79404

#### **ODESSA**

(866) 359-MACK  
2441 East I-20  
Odessa, TX 79766

#### **SAN ANGELO**

(877) 861-2388  
829 North Bell St.  
San Angelo, TX 76903

#### **SAN ANTONIO (I-10)**

(210) 661-4121  
4562 IH10 East  
San Antonio, TX 78219

### **SAN ANTONIO (I-35)**

(210) 646-6225  
11215 N. Weidner Rd.  
San Antonio, TX 78233

### **TYE (ABILENE)**

(866) 341-MACK  
1002 S. Access Rd.  
(Exit 278 I-20)  
Tye, TX 79563

### **WICHITA FALLS**

(866) 369-MACK  
4520 N. W. Freeway  
Wichita Falls, TX 76306

### KANSAS

#### **GARDEN CITY\***

*(PARTS & SERVICE LOCATION)*  
(877) 999-1449  
2509 N Taylor Ave  
Garden City, KS 67846

#### **HAYS**

(888) 629-MACK  
2101 Commerce Parkway  
Hays, KS 67601

#### **SALINA**

(785) 714-4159  
1645 Copper Court  
Salina, KS 67401

#### **WICHITA**

(877) 246-1671  
4343 South West Street  
Wichita, KS 67217

### NEW MEXICO

#### **ALBUQUERQUE**

(866) 370-MACK  
8101 Daytona Rd. NW  
Albuquerque, NM 87121

#### **FARMINGTON**

(866) 349-MACK  
4050 Bloomfield Hwy  
Farmington, NM 87401

#### **HOBBS**

(866) 351-MACK  
2121 NW County Rd  
Hobbs, NM 88240

### OKLAHOMA

#### **ARDMORE\***

*(PARTS AND MOBILE SERVICE LOCATION ONLY)*  
(888) 999-9316  
3312 Prairie Valley Rd.  
Ardmore, OK 73401

#### **BIG CABIN**

(918) 783-5159  
32046 S Hwy 69  
Big Cabin, OK 74332

#### **ENID**

(800) 375-6225  
5913 E. Owen K. Garriott Rd.  
Enid, OK 73701

#### **OKLAHOMA CITY**

(866) 360-MACK  
10120 West Reno Avenue  
Oklahoma City, OK 73127

#### **TULSA**

(877) 493-6025  
5301 W. 60th  
Tulsa, OK 74107

### COLORADO

#### **DENVER (COMMERCE CITY)**

(866) 310-6225  
7626 Brighton Road  
Commerce City, CO 80022

#### **FOUNTAIN**

(877) 589-6256  
6145 Champlin Drive  
Fountain, CO 80817

#### **GREELEY\***

*(PARTS ONLY LOCATION)*  
(877) 455-3494  
600 26th St.  
Garden City, CO 80631

### LOUISIANA

#### **BALL**

*(TRAILER REPAIR SHOP)*  
(318) 641-0290  
4303 Pardue Rd,  
Ball, LA 71405

### **PINEVILLE**

(318) 640-2098  
4170 Pardue Rd  
Pineville, LA 71360

### **MONROE**

(877) 801-2982  
6500 Frontage Rd.  
Monroe, LA 71202

### **SHREVEPORT**

(877) 369-0906  
7600 Greenwood Road  
Shreveport, LA 71119

### ARKANSAS

#### **LOWELL**

(479) 770-6040  
324 S. Bloomington St.  
Lowell, AR 72745

#### **POTTSVILLE**

(479) 498-8260  
620 Mountain Base Rd.  
Pottsville, AR 72858

#### **VAN BUREN**

(479) 782-8281  
209 Rena Rd.  
Van Buren, AR 72956

### WASHINGTON

#### **ELLENSBURG**

(509) 962-8881  
1711 US Highway 97  
Ellensburg, WA 98926

#### **WENATCHEE**

(509) 665-8383  
1231 S. Wenatchee Ave.  
Wenatchee, WA 98801

#### **YAKIMA**

(509) 575-8888  
2003 E Viola Ave,  
Yakima, WA 98901

9471 I-40 East Exit #76  
Amarillo, TX 79118

Change Service Requested

# PREVENTATIVE MAINTENANCE

STOP BY AND SEE FACTORY-TRAINED PARTS AND  
SERVICE STAFF ON OUR SERVICE PM SPECIALS.



**SMALL CHANGES TODAY TO PREVENT BIG PROBLEMS TOMORROW**